

Amazon III W

K2F-280 DN3W

PRODUCT SHEET

 Product certified by: 

FEATURES

Model	K2F-280 DN3W
Max. indoor units	24
Cooling capacity	28 kW
Cooling power input	6,10 kW
Heating capacity	31,50 kW
Heating power input	5,83 kW
Water flow	6 m ³ /h
Sound pressure	52 dB(A)
Working range (cooling/heating)	7°C - 45°C
Refrigerating pipes	Ø1/2" - Ø1" - Ø1/4"
Refrigerant charge	2 kg
Power supply	380-415 V / 3 / 50 Hz
Max. input	23 A
Power wiring	(4+T)x4 mm ²
Shielded communication wiring	3x1,50 mm ²

WIRING DIAGRAM

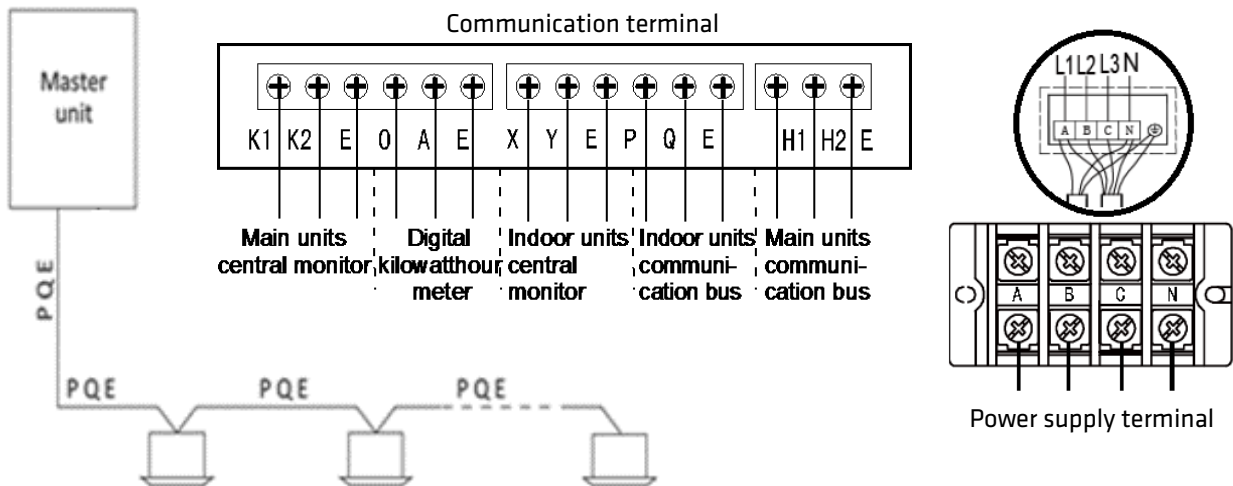

NOTES:

- (1) The data and specifications present in this sheet may vary without notice.
- (2) The images on this sheet are indicative and may be different from the final machine.

PIPELINE LENGTH

Max. pipe length		300 m
Max. distance between outdoor unit and further indoor unit	Real	120 m
	Equivalent	150 m
From first branch joint to the further indoor unit		40 m
Height difference	Outdoor unit over	50 m
	Outdoor unit below	40 m
Height difference between indoor units		30 m

DIMENSIONS & WEIGHT

Width	780 mm
Height	1.000 mm
Depth	550 mm
Weight	146 kg

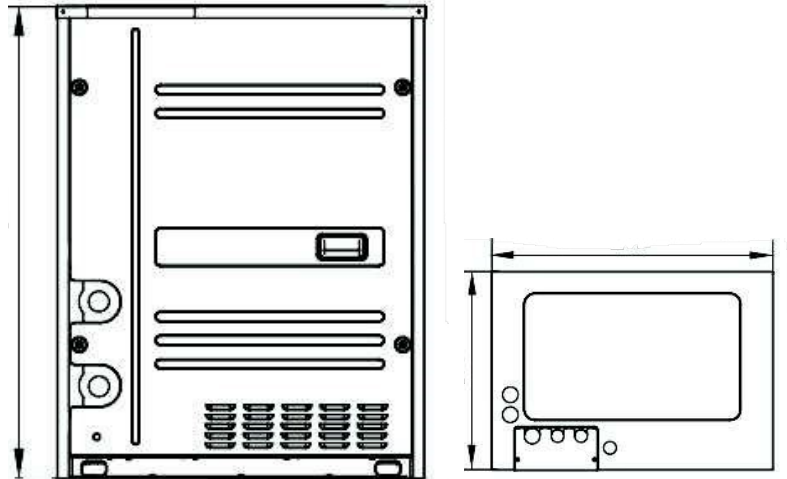

INSTALLATION

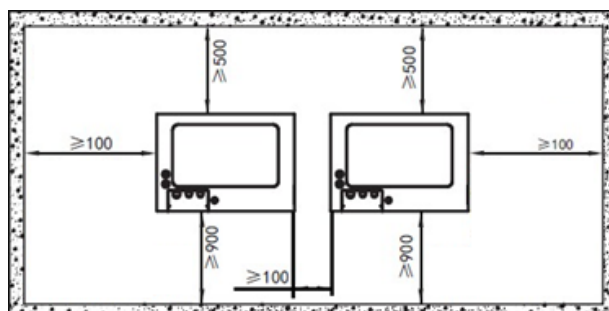
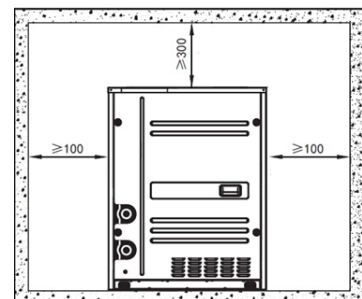
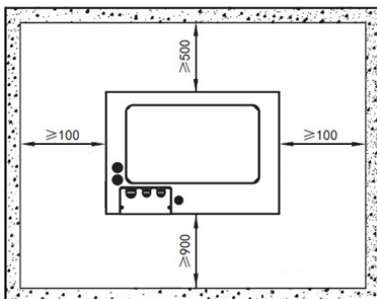

Amazon III W

K2F-335 DN3W

PRODUCT SHEET

 Product certified by: 

FEATURES

Model	K2F-335 DN3W
Max. indoor units	29
Cooling capacity	33,50 kW
Cooling power input	8 kW
Heating capacity	37,50 kW
Heating power input	7,80 kW
Water flow	7,20 m ³ /h
Sound pressure	52 dB(A)
Working range (cooling/heating)	7°C - 45°C
Refrigerating pipes	Ø5/8" - Ø1 1/4" - Ø1/4"
Refrigerant charge	2 kg
Power supply	380-415 V / 3 / 50 Hz
Max. input	23 A
Power wiring	(4+T)x6 mm ²
Shielded communication wiring	3x1,50 mm ²

WIRING DIAGRAM

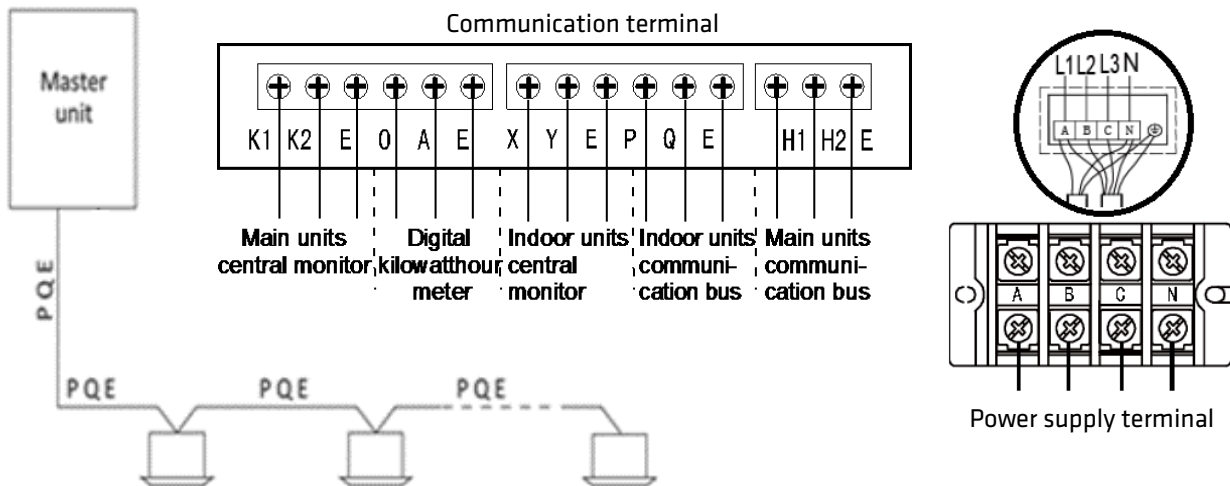

NOTES:

- (1) The data and specifications present in this sheet may vary without notice.
- (2) The images on this sheet are indicative and may be different from the final machine.

PIPELINE LENGTH

Max. pipe length		300 m
Max. distance between outdoor unit and further indoor unit	Real	120 m
	Equivalent	150 m
From first branch joint to the further indoor unit		40 m
Height difference	Outdoor unit over	50 m
	Outdoor unit below	40 m
Height difference between indoor units		30 m

DIMENSIONS & WEIGHT

Width	780 mm
Height	1.000 mm
Depth	550 mm
Weight	147 kg

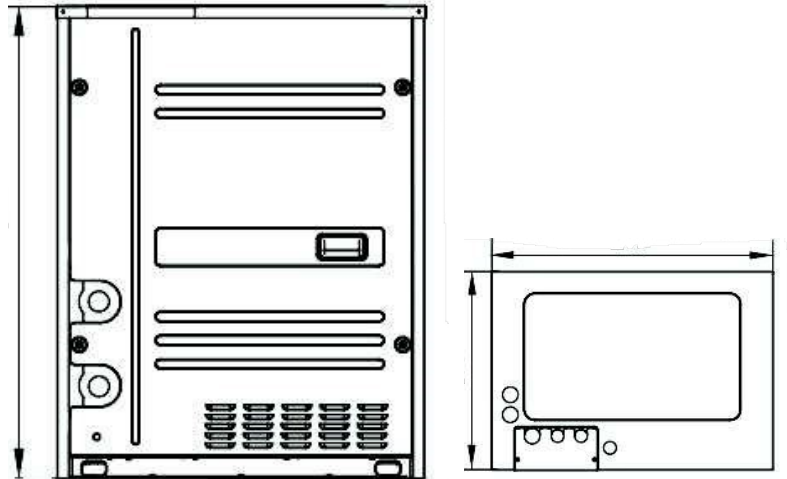

INSTALLATION

