

Halton Exe Light Rectangular (ELR) – Fire damper (E 120 S)

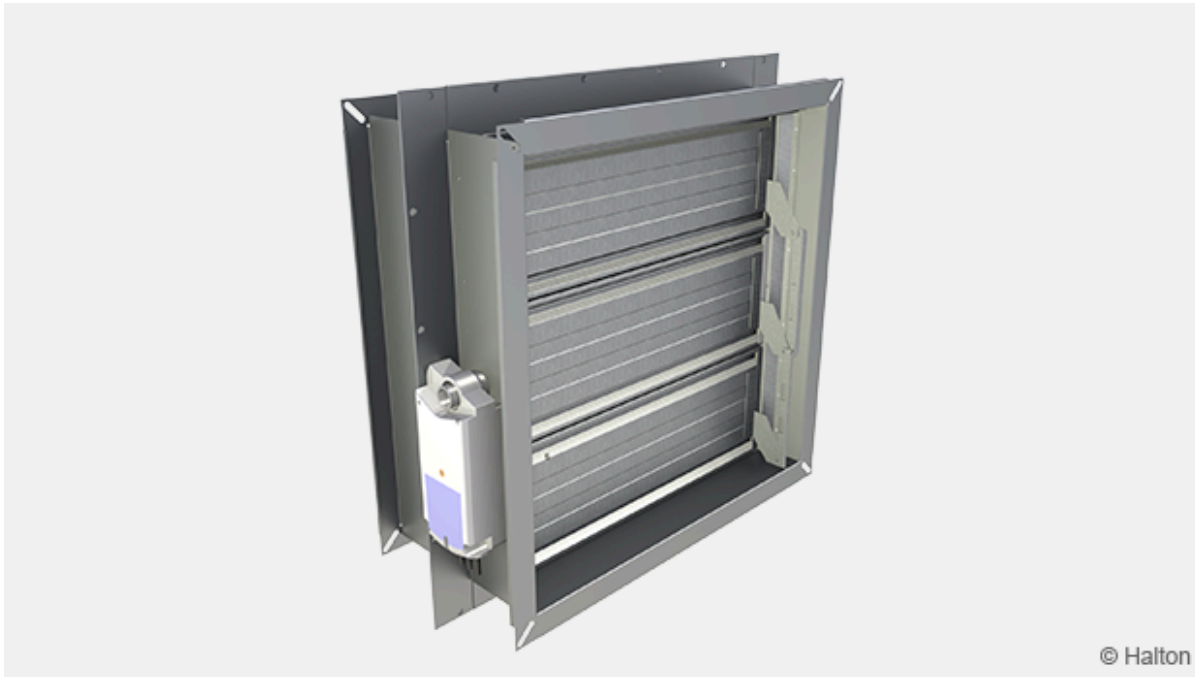

Overview

This non-insulated fire damper is one of the shortest in the market and so utilising minimal space. The light construction makes installation easy. Installation option up to 1.0 meter away from the structure has been certified. Fire resistance class is provided up to E 120 S requirements in all installation options.

Features

- Supplied with electrical spring return actuator (24 V or 230 V option) or 0 -10 V modulating actuator (24 V)
- Standard sizes from 200x200mm up to 1000x1000 mm are available
- Maximum air speed through fire damper in open position is 15 m/s
- Suitable for use in ducts with a maximum pressure difference of 3300 Pa
- Material options galvanised or stainless steel (EN 1.4404/AISI 316L) available
- No spare parts or additional installation frames needed, regardless of installation method

Installation options

- Vertical (wall) and horizontal (ceiling/floor) installation
- Spindle of the blade and the operating model can be installed in vertical or horizontal position in wall installation
- Can be installed up to 1.0 m away from separate element

- Installation in concrete, masonry or lightweight structure with fire resistance classes up to E 120

Standards

This product complies with the following standards:

- CE certified according to product standard EN 15650
- Fire classification according to EN 13501-3+A1 standard
E 120 (v_e h_o i↔o) S, E 60 (h_o i↔o) S
- Fire testing according to EN 1366-2
- CE certificate of constancy of performance, No: 2434-CPR-0037
- Declaration of Performance, No: 10030-ELR-2019/04/17
- Leakage through closed fire damper blade class 4 according to EN 1751
- Damper casing tightness class C according to EN 1751
- Manufactured in accordance with ISO 9001 quality system

Dimensions and weight

Rectangular duct connections

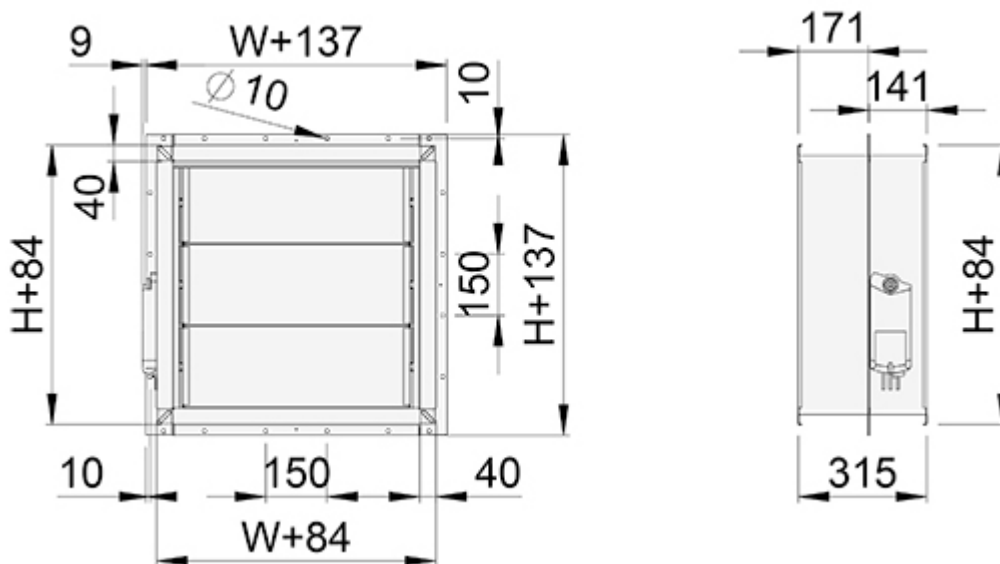

W = Width (mm)

200, 250, 300, 350, 400, 450, 500, 550,
600, 700, 800, +50, ... 1000

H = Height (mm)

200, 300, 350, 400, 450, 500, 550,
600, +50, ... 1000

With circular duct connections

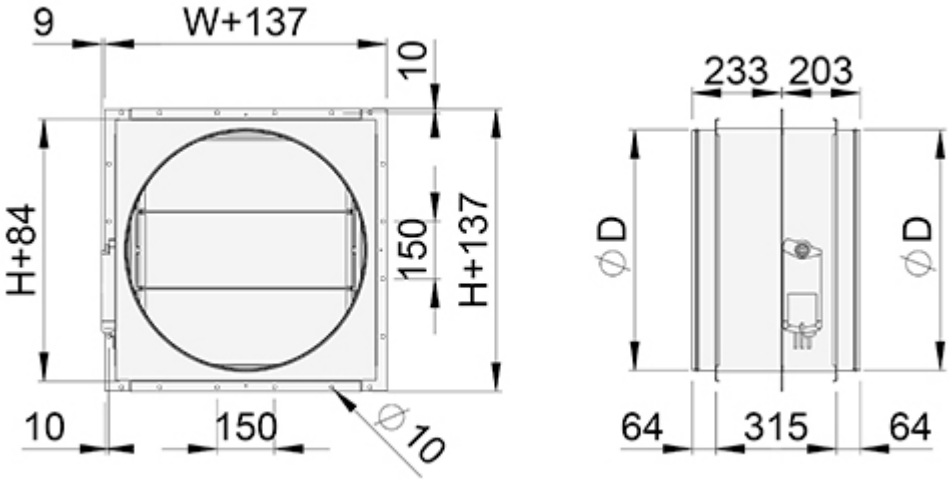

D	H	W
630	600	600
800	800	800
1000	1000	1000
1250	1000	1000

Weight (kg)

Rectangular duct connections

H	W												
	200	250	300	350	400	450	500	550	600	700	800	900	1000
200	5.9	6.5	7.2	7.9	8.5	9.2	9.8	10.4	11.0	12.3	13.6	14.9	16.1
300	9.4	9.7	10.0	10.2	10.3	11.9	11.8	12.5	13.3	14.8	16.3	17.8	19.3
350	10.8	11.0	11.2	11.3	11.4	12.7	13.9	14.4	14.9	16.7	18.4	20.2	21.9
400	11.2	11.8	12.4	12.9	13.5	14.0	14.6	15.6	16.6	18.6	20.6	22.6	24.6
450	11.6	12.2	12.8	13.3	13.9	15.0	16.0	16.8	17.6	18.3	20.9	22.7	24.4
500	12.6	13.3	14.0	14.6	15.1	16.1	17.3	18.4	19.6	22.0	24.3	26.7	29.0
550	13.6	14.4	15.2	15.9	16.6	17.5	18.7	20.0	21.3	23.9	26.5	29.1	31.7
600	14.4	15.4	16.4	16.9	17.8	20.9	22.7	23.3	23.7	26.7	29.7	32.7	35.6
700	16.2	16.8	17.4	18.0	19.6	21.1	22.8	24.5	26.0	29.2	32.4	35.6	38.8
800	18.0	18.6	19.2	20.8	22.4	24.4	26.3	28.4	30.1	33.9	37.7	41.6	45.4
900	19.8	20.4	21.0	22.6	24.2	26.2	28.3	30.3	32.3	36.4	40.4	44.5	48.5
1000	21.6	22.2	22.8	24.4	27.1	29.6	31.8	33.9	36.5	41.1	45.8	50.5	55.2

With circular duct connections

D	kg
630	28.0
800	43.0
1000	61.0
1250	69.9

Material

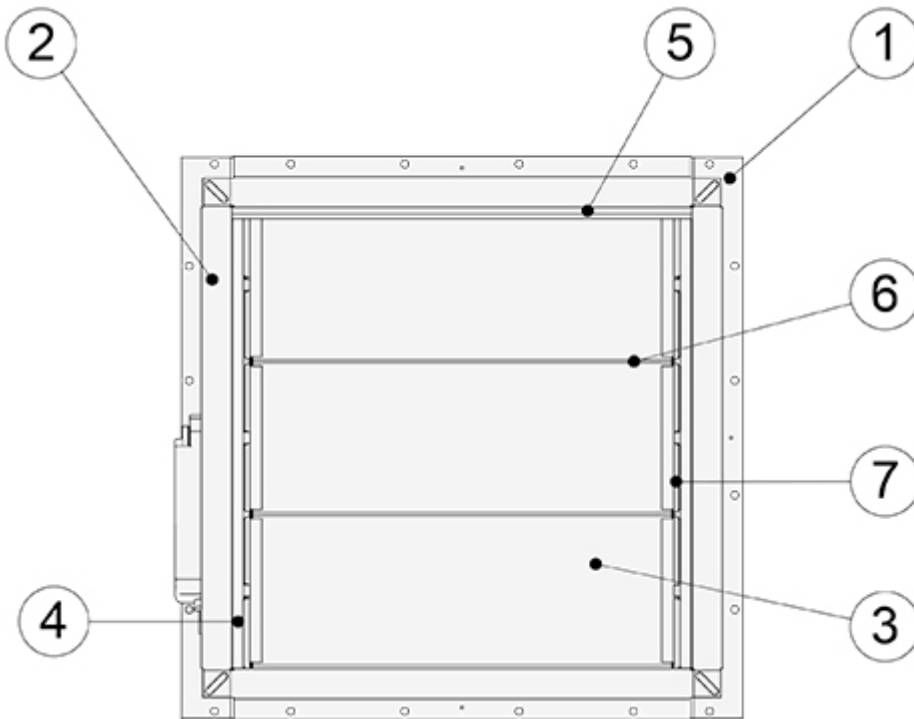

Number	Part	Material	Note
1, 2	Casing	Galvanised steel	Stainless steel as option (EN 1.4404/AISI 316L)
3	Blade	Galvanised steel	Stainless steel as option (EN 1.4404/AISI 316L)
4	Bearing list	Galvanised steel	Stainless steel as option (EN 1.4404/AISI 316L)
5	Support beam	Galvanised steel	Stainless steel as option (EN 1.4404/AISI 316L)
6	Gasket (wide side)	e-cloth/expansive material	–
7	Gasket (height side)	e-cloth	–

Operating Models

Electric actuator

In the electric actuator (24 V and 230 V) system when a signal from building automation reaches the actuator or the fuse reacts to a rise in temperature (72 °C) power supply is switched off and the spring closes the blade of the damper. When the power supply is turned back on (e.g. during routine testing), the actuator opens the blade. In case of a power failure, the mechanical spring of the

actuator ensures the failsafe function by closing the blade.

The actuators are equipped with built-in limit switches for both open and closed position and have a visual position indicator.

The fuse can be replaced from outside the device.

AC/DC 24 V (N1)

The Halton Exe Light Rectangular fire damper with the 24 V electric actuator option must be connected to buildings fire damper management control system, e.g. We recommend our Modbus based network solution Halton Safe Management (HSM) control and testing system. This system enables the use of smoke detectors in ductwork or room spaces.

Operationally, when the Halton Safe Management (HSM) receives a signal from the fire alarm or smoke detector the power supply is turned off and the spring return actuator drives the damper blade to closed position. When the power supply is turned back on (e.g. during routine testing) the actuator drives the damper blade to open position.

The fire damper can also be connected to other commonly used building automation systems.

AC 230 V (N2)

The Halton Exe Light Rectangular fire damper with the 230 V electric actuator option must be connected to buildings fire damper management control system.

AC 24 V / DC 24...48 V, modulating (N3)

The Halton Exe Light Rectangular fire damper with modulating actuator has two features: It can be used for VAV purposes in air ventilation systems and at same time as a fire damper.

The fire damper must be connected to buildings fire damper management control system.

Order code	Operating model	Damper size (WxH, mm)	Operating voltage	Limit switch
N1	GNA 126.1E-T12, 7 Nm	200×200 – 1000×1000	AC/DC 24 V	✓
N2	GNA 326.1E-T12, 7 Nm	200×200 – 1000×1000	AC 230 V	✓
N3	GNA 166.1E/T12, 7 Nm (modulating)	200×200 – 1000×1000	AC/DC 24 V	✓

Function

The Halton Exe Light Rectangular fire damper is CE certified for vertical (v_e) and horizontal (h_o) installation in concrete, masonry or lightweight structures. It fulfils the fire resistance class up **E 120** ($v_e h_o i \leftrightarrow o$) **S** requirements.

General

Fire dampers are shutters in ventilation duct systems and prevent spreading of the fire and smoke from one fire department to the other. They are equipped with an electric operating model (actuator). A fuse reacts to a rise in temperature, causing a spring-return damper blade to close position.

A fire damper with electrical actuator must be connected to a common fire alarm or building automation system.

In the electric actuator (24 V or 230 V) system, when a signal from building automation reaches the actuator or the fuse reacts to a rise in temperature (72 °C), the power supply is switched off, the spring closes the damper blade and seals the duct fire and smoke tightly. When the power supply is turned back on (e.g. during routine testing), the actuator opens the damper blade. The actuator is equipped with built-in limit switches for both open and closed position.

Fire damper management system

It is recommended that the fire damper with an electrical actuator is connected to an automatic fire damper management system, e.g. Halton Safe Management (HSM) with operating voltage AC 24 V. Testing for fire dampers can be done automatically in Halton Safe Management (HSM).

Only fire damper with 24 V electric actuator can be connected to the Halton Safe Management (HSM) control and testing system. The Halton Safe Management (HSM) enables the use of smoke detectors in ductwork or in the rooms.

Operationally, when the Halton Safe Management (HSM) receives a signal from the fire alarm or smoke detector the power supply is turned off and the spring return actuator drives the damper blade to the closed position. When the power supply is reinstated (e.g. during routine testing) the actuator drives the damper blade to the open position.

The Halton Exe Light Rectangular fire damper can also be connected to common building automation systems.

Installation

Please see/download Installation Guide for this fire damper from section Downloads.

Servicing

No regular maintenance is required for the product.

To ensure proper operation of fire dampers, inspection must be carried out regularly according to local building codes. The minimum recommended inspection period is **every 6 months**. Documentation of testing needs has to be saved for future needs.

A fire damper with electrical actuator must be connected to a common fire alarm or building automation system.

It is recommended that the fire damper with an electrical actuator is connected to an automatic fire damper management system, e.g. Halton Safe Management (HSM) with operating voltage AC 24 V. Testing for fire dampers can be done automatically in Halton Safe Management (HSM).

The fuse of a fire damper equipped with an electric actuator must be replaced if the fuse has been released because of a rise of temperature in the duct. The fuse can be changed from outside the fire damper.

The actuator include position indicators, open and close

Upon failure during testing of the fire damper, maintenance service shall be ordered from an authorised Halton representative to ensure appropriate operation of the product.

Specification

The fire damper is CE certified and marked according to the standard EN15650 and fire tested according to EN 1366-2 standard.

A fire damper of maximum fire resistance class **E 120 (v_e h_o i↔o) S** requirements.

The fire damper casing complies with the tightness requirements for EN 1751 class C. Leakage through closed fire damper blade class 4 according to EN 1751

The fire damper can be installed both vertical and horizontal position in concrete, masonry or lightweight structures.

The spindle of the blade and the operating model can be installed in vertical or horizontal position in wall installation.

The fire damper can be installed away from the separate element up to 1.0 metre (E 120 S).

The casing and the blade of the fire damper are made of galvanised or stainless steel (EN 1.4404/ AISI 316L).

The fuse shall be activated at 72 °C.

The fire damper with electric operating model includes position indicators, open and close and is equipped with built-in limit switches for both open and closed position.

Order Code

ELR/S-W-H-D; MA-OP-FU-ZT

S = Type of Duct Connection

- R Rectangular
- C Circular

W = Width of Duct Connection

200, +50, ..., 1000

H = Height of Duct Connection

200, 300, +50, ..., 1000

D = Size of Duct Connection (circular type)

630, 800, 1000, 1250

Other Options and Accessories

MA = Material

GS Galvanised steel
AS Stainless steel (EN 1.4404/AISI 316L)

OP = Operating Model

N1 GNA126.1E/T12 (72 °C) 24 V, 7 Nm
N2 GNA326.1E/T12 (72 °C) 230 V, 7 Nm
N3 GNA166.1E/T12 modulating (72 °C) 24 V, 7 Nm

FU = Fuse Release Temperature

72 72 °C

ZT = Tailored Product (ETO)

N No
Y Yes

Code Example

ELR/R-200-200, MA=GS, OP=N1, FU=72, ZT=N